

# QuadroDesign

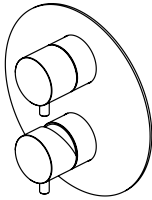

12 45

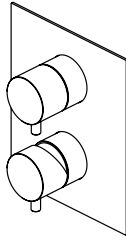

12 46



12 47

---

**Gruppo incasso miscelatore e deviatore a due vie di uscita**  
**Built-in mixer set with 2 way diverter**  
**Wandmischer mit 2 Wegeumstellung**  
**Grupo empotrado con mezclador e inversor 2 salidas**  
**Groupe mitigeur encastré avec inverseur 2 voies**

---

**Istruzioni di montaggio**  
**Assembling instructions**  
**Installationsanleitung**  
**Instructions de montage**  
**Instrucciones de montaje**



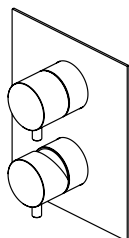
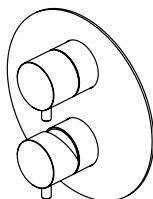

---

**Gruppo incasso miscelatore e deviatore a due vie di uscita**

**Built-in mixer set with 2 way diverter**

**Wandmischer mit 2 Wegeumstellung**

**Grupo empotrado con mezclador e inversor 2 salidas**

**Groupe mitigeur encastré avec inverseur 2 voies**

---

**Istruzioni di montaggio**

**Assembling instructions**

**Installationsanleitung**

**Instructions de montage**

**Instrucciones de montaje**

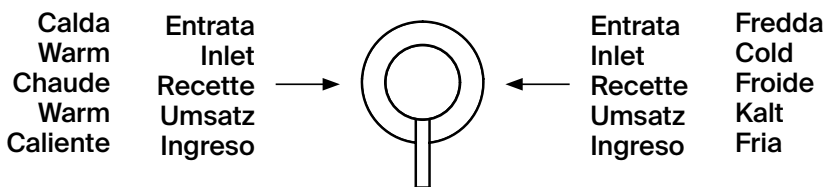
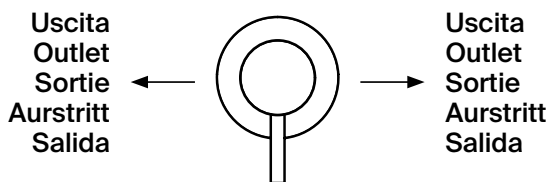

**Mettere in pressione l'impianto per verificarne la tenuta e la corretta installazione.**

**Put the system under pressure in order to verify the hold and correct installation.**

**L'installation sous pression pour en vérifier l'étanchéité et le bon fonctionnement.**

**Installation unter Druck stellen um das Fassungsvermögen und den korrekten Einbau zu überprüfen.**

**Presurizar la planta para comprobar su retención correcta.**

**Profondità Massima**  
**Maximum Depth**  
**Profondeur Maximale**  
**Maximale Tiefe**  
**Profundidad Máxima**

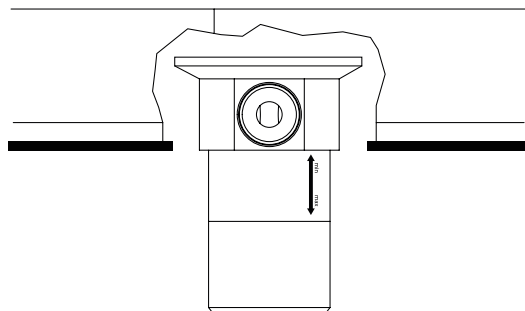

**Profondità Massima**  
**Maximum Depth**  
**Profondeur Maximale**  
**Maximale Tiefe**  
**Profundidad Máxima**

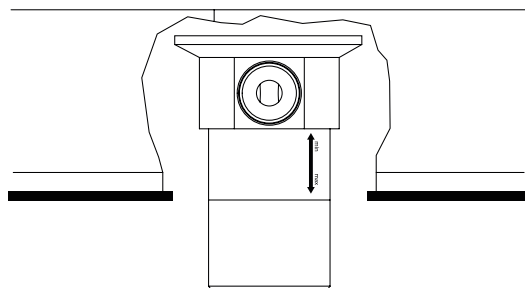

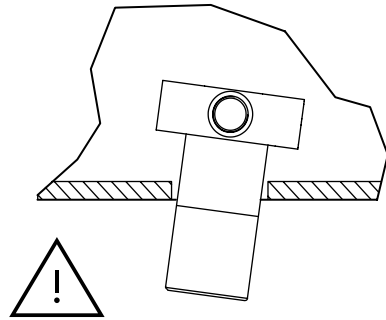
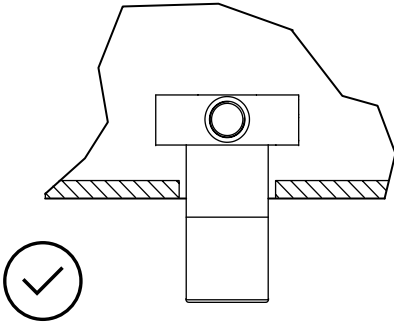
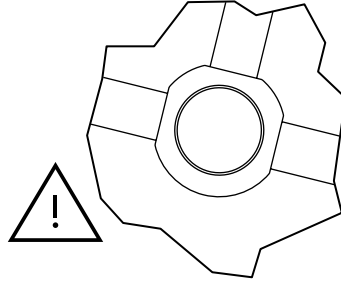
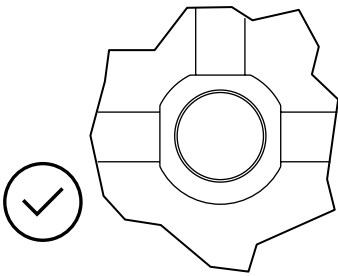

Con l'aiuto di una livella posizionare correttamente il corpo incasso sia in orizzontale che in verticale seguendo le specifiche delle figure seguenti prestando particolare attenzione alla profondità d'incasso minima e massima riportate sul cappuccio di protezione in plastica nera.

With the help of a level, correctly position the built-in body both horizontally and vertically according to the specifications of the following indications, paying particular attention to the minimum and maximum mounting depth information on the protective black plastic covering.

Mithilfe einer Wasserwaage den Einbaukörper sowohl horizontal als auch vertikal korrekt positionieren und hierbei die nachfolgenden spezifischen Abbildungen befolgen. Unbedingt die auf den Etiketten der Schutzvorrichtungen ersichtliche minimale und maximale Einbautiefe einhalten.

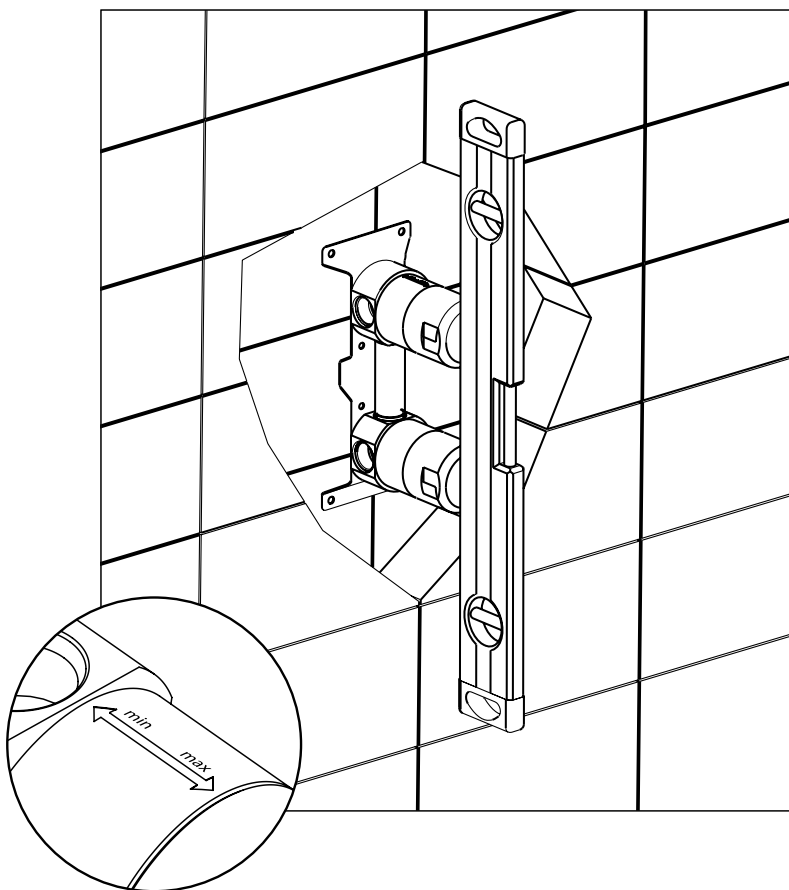

Con la ayuda de un nivel, posicionar correctamente el cuerpo a empotrar de manera horizontal y vertical siguiendo las indicaciones de las figuras a continuación prestando especial atención a la profundidad del empotrado mínimo y máximo indicada en las etiquetas ubicadas en la protección en plastica.

À l'aide d'un niveau, placer correctement le corps à encastrent aussi bien à l'horizontale qu'à la verticale en suivant les caractéristiques des figures ci-dessous et en prêtant attention à la profondeur d'encastrement minimum et maximum indiquées sur la protection noire.

1.

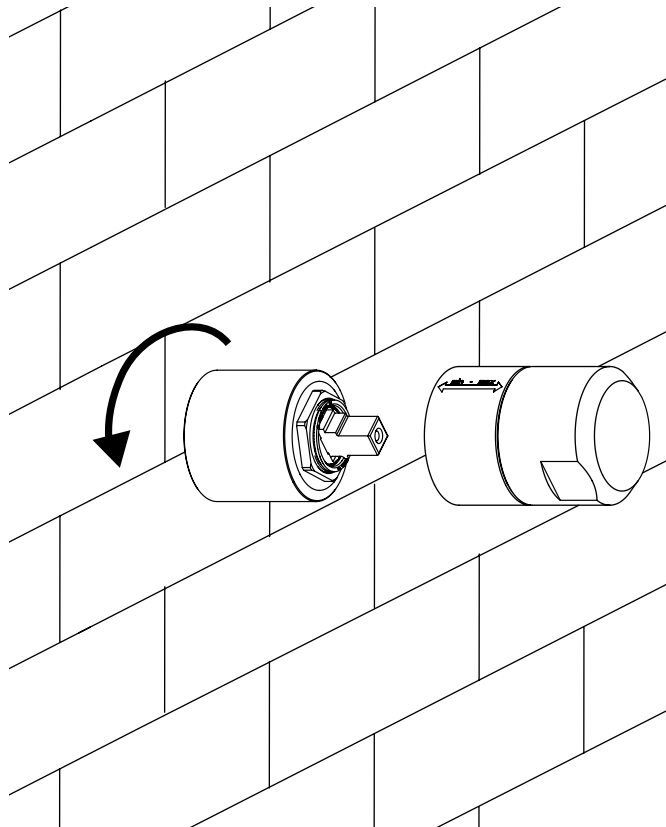

Rimuovere la protezione in plastica nera una volta completato il lavoro di rivestimento.  
Remove the black plastic protection once the facing of the wall is completed.  
Retirez la protection en plastique noir à revêtement finis.  
Entfernen Sie die schwarzen Kunststoff-Schutz, sobald die Beschichtungsarbeiten .  
Retire la protección de plástico negro una vez que el trabajo de revestimiento.

---



2.

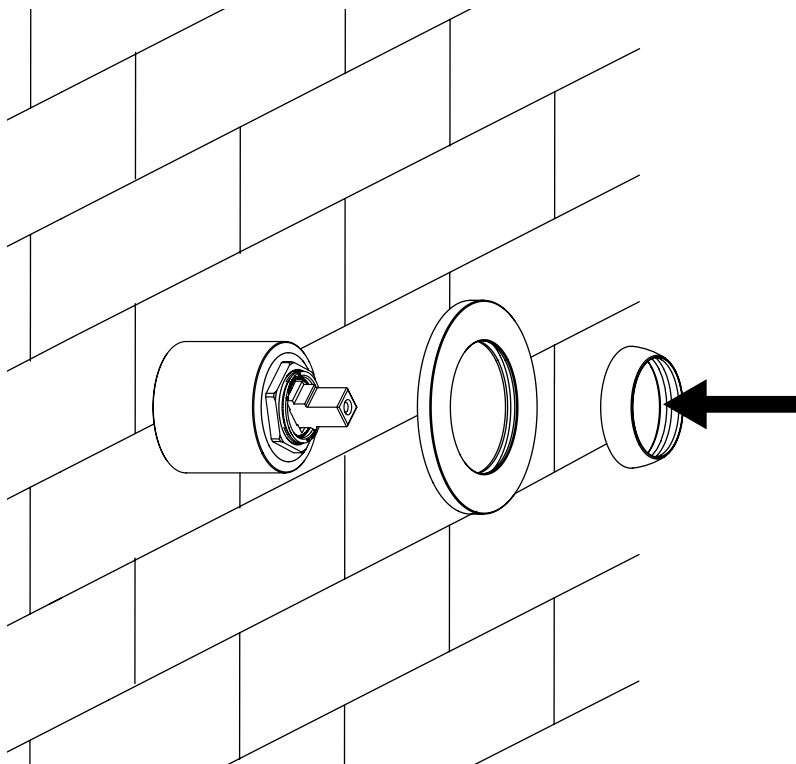

Inserire la rosetta e avvitare il copri ghiera di fissaggio al rubinetto.

Insert the steel plate and screw the cap onto the tap.

Insérer la rondelle et visser le couvercle écrou de fixation au robinet.

Legen Sie die Unterlegscheibe und schrauben Sie die Überwurfmutter an den Wasserhahn zu befestigen.

Introducir la arandela y el tornillo de la tapa de la tuerca de fijación al grifo.

### 3.

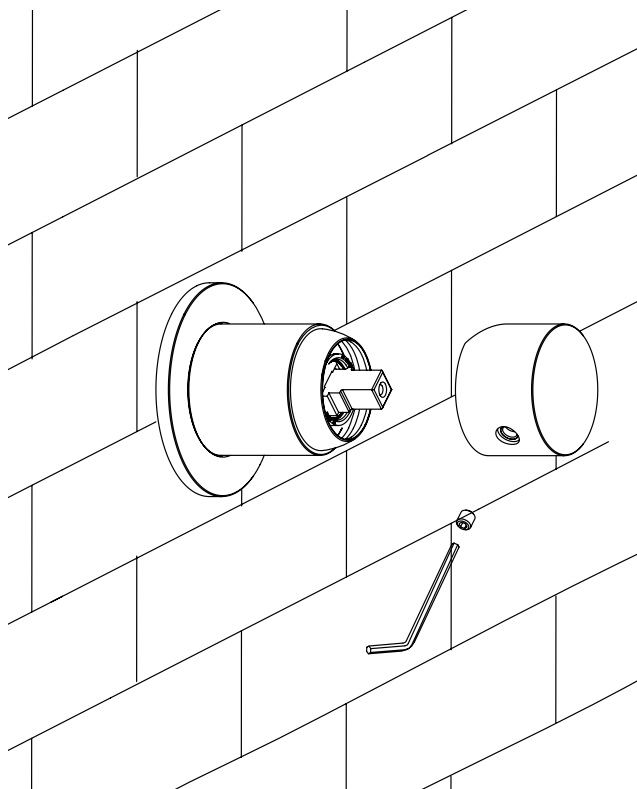

Svitare il pin della leva, svitare la brugola pre-inserita nel corpo della leva con una chiave per brugola, appoggiare la leva alla cartuccia e riavvitare.

Unscrew the pin of the lever, unscrew the allen key pre-inserted in the body of the lever with a key, insert onto the cartridge, and screw back the allen key again.

Dévissez la goupille de levier, dévissez le Allen pré-insérée dans le corps du levier avec une clé allen pour le nettoyage, placez le levier de la cartouche et la vis.

Schrauben Sie den Hebelstift, schrauben Sie die Allen vorge eingeführt in den Körper des Hebels mit einem Inbusschlüssel zur Reinigung, legen Sie den Hebel in die Patrone und Schraube.

Desenroscar el pasador de la palanca, desenroscar el Allen pre-insertado en el cuerpo de la

---

4.

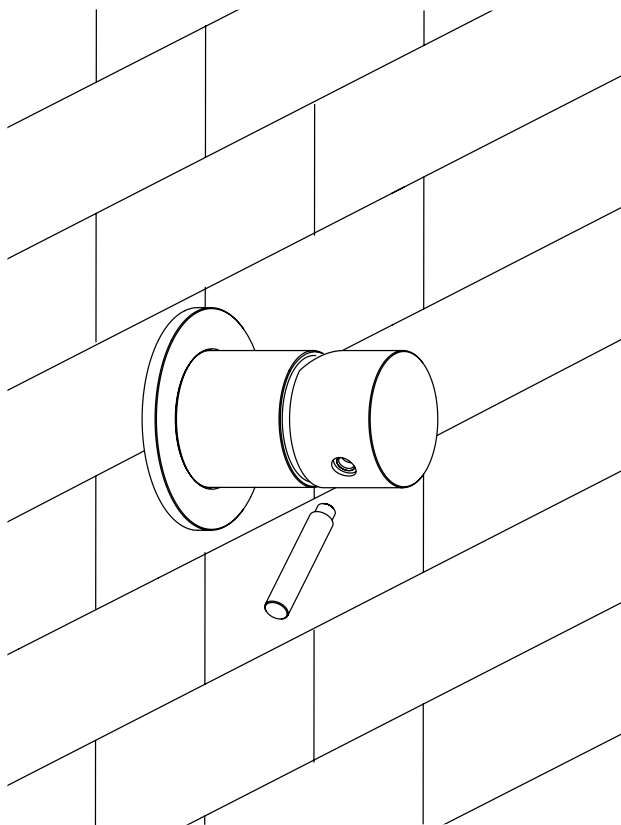

Avvitare il pin alla leva.

Screw back the pin onto the lever.

Vissez la broche arrière sur le levier.

Schrauben Sie den Stift wieder auf den Hebel.

Atornille el pasador de vuelta a la palanca.

---

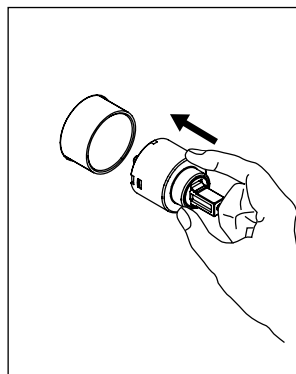
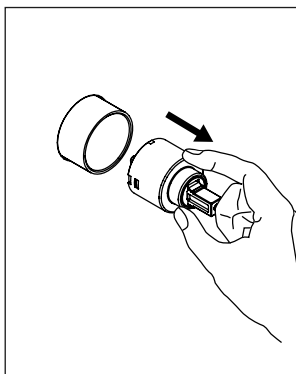
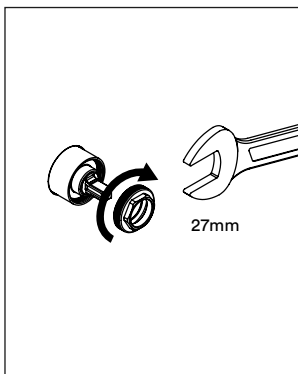
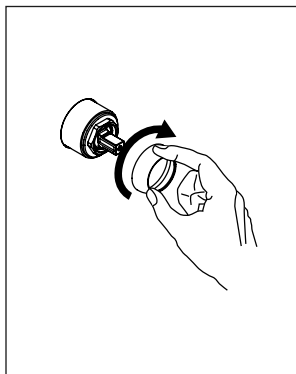
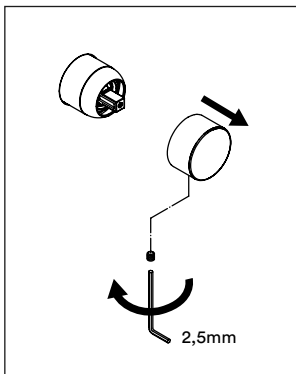
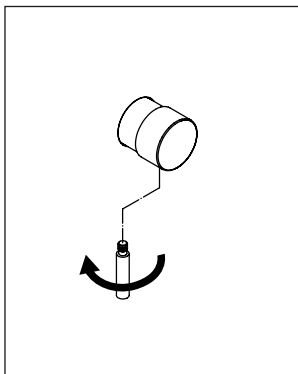

Rimontare seguendo il procedimento inverso.

Replace following the instructions in reverse order.

Re-installer au contraire du procédé.

Die umgekehrte Vorgehensweise folgen um die Teil wieder zu installieren.

Colocar según el procedimiento inverso.

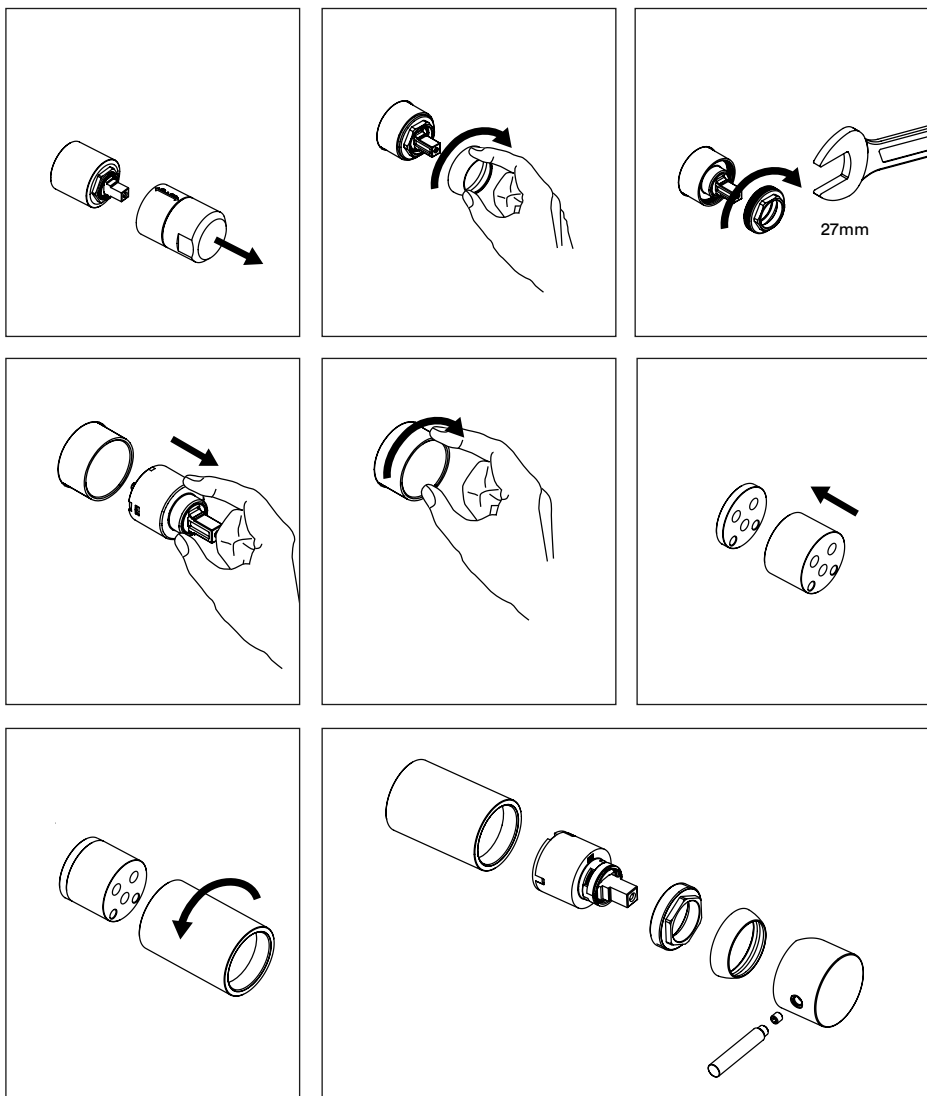

Nel caso si fosse installato il pezzo troppo all'interno del muro si può far richiesta della prolunga. If you installed the piece too inside the wall you can request the extension.

Si vous aviez la pièce trop installée à l'intérieur du mur, vous pouvez en faire la demande de l'extension.

Wenn Sie hatte auch das Stück in der Wand installiert ist, können Sie die Anforderung der Verlängerung zu machen.

Si hubieras la pieza demasiado instalado dentro de la pared se puede hacer la solicitud de la prórroga.





Quadro srl  
via Bonetto 40  
28017 San Maurizio d'Op.  
(NO) Italy  
Tel 0039.0322.96266  
Fax 0039.0322.967264  
info@quadrodesign.it  
www.quadrodesign.it